



Lecture 1

COMPUTER ARCHITECTURE

Sommersemester 2000

Leitung: Prof. Dr. Miroslaw Malek

www.informatik.hu-berlin.de/~rok/ca

RECHNERARCHITEKTUR

AN DER HUMBOLDT-UNIVERSITÄT ZU BERLIN
SOMMERSEMESTER 2000

Leiter: Prof. Dr. Mirosław Malek
Humboldt-Universität zu Berlin
Institut für Informatik
Rechnerorganisation und Kommunikation
Rudower Chaussee 25, Haus IV

Vorlesung:	Mo	16 -18	UL 6, 2097	M. Malek
	Mi	10 -12	UL 6, 3094	
Übungen:	Mi	12 -14	DOR 24, 311	P. Ibach
	Do	8 -10	DOR 24, 405	A. Polze
	Do	14 -16	DOR 24, 212	M. Werner
	Do	14 -16	DOR 24, 403	S. Sommer*

* (Studierende, die nicht die VL Techn. Inf. 1 besucht haben, u. a. Magister 2. HF, schreiben sich bitte in diese Übungsgruppe ein)

Kursinhalt: Grundwissen Rechnerarchitektur und -organisation

Termine:	1. Zwischenklausur	31.5.2000
	2. Aufgaben	zweiwöchentlich
	3. Team-Projekt	Abgabe 3.7.2000
	4. Projektpresentation	10-13.7.2000
	5. Abschlussklausur	19.7.2000

Voraussetzung für die Zulassung zur Abschlussklausur (für Vornote): mindestens 50% Punkte in jeweils jeder Kategorie

weitere Infos unter www.informatik.hu-berlin.de/~rok/ca

RECHNERARCHITEKTUR

- Literatur
englisch
- V.C. Hamacher, Z.G. Vranesic and S.G. Zaky, *Computer Organization*, McGraw-Hill, 1996 (4. ed.)
 - J.L. Hennessy and D. A. Patterson, *Computer Architecture: a Quantitative Approach*, Morgan Kaufmann Publishers, 1998, 2nd ed., auch in deutscher Sprache: J.L. Hennessy und D. A. Patterson, *Rechnerarchitektur: Analyse, Entwurf, Implementierung, Bewertung*, Vieweg, 1994
 - A.S. Tanenbaum, *Computer Organization*, Prentice-Hall 1999 (4. ed.), auch in Deutsch: *Computer Architektur*, Prentice-Hall, 1999
 - J.P. Hayes, *Computer Architecture and Organization*, McGraw-Hill, 1998 (3rd ed.)
 - M.M. Mano, *Computer Systems Architecture*, Prentice Hall, 1993
 - H.S. Stone, *High-Performance Computer Architecture*, Addison-Wesley, 1987
 - H.P. Messmer, *The Indispensable Pentium Book*, Addison-Wesley, 3rd ed., 1997
 - R.Y. Kasin, *Advanced Computer Architecture, A System Design Approach*, Prentice-Hall, 1996
- Literatur
deutsch
- H. Liebig, T. Flik: *Rechnerorganisation : Prinzipien, Strukturen, Algorithmen*, Springer 1993

COURSE OBJECTIVES

The future of computing is the computer that talks, listens, sees and learns.

“Bill Gates“.

- **Introduction to Computer Architecture**
 - Terminology
 - Basic concepts
 - Principles
- **Single Processor Architecture**
 - Specification
 - Designs
 - Implementation
- **Other Concepts**
 - Memory hierarchy
 - Pipelining
 - Parallel processing
- **Brief Introduction to...**
 - Parallel computing
 - Distributed computing
 - Networking

COMPUTER ARCHITECTURE

1. Introduction and Background

- World of computers
- Brief history of digital computers
- Functional units
- Basic operational concepts and definitions
- Performance and cost

2. Addressing Methods and Machine Programming Concepts

- Addresses
- Addressing modes
- Simple I/O programming
- Pushdown stacks vs. Register organization

3. Instruction Set Design

- Op-codes
- Minimal instruction sets
- CISC vs. RISC

4. The Processing Unit and Microprogrammed Control

- Fundamental concepts
- Sequencing of control signals
- Concepts of microprogramming
- Microinstruction formats
- Hardwired vs. microprogrammed control units

5. Arithmetic Unit (Unit Operator)

- Number representations
- Addition, subtraction, multiplication, division algorithms and hardware implementation
- Serial, parallel, decimal, floating-point arithmetic units
- Logic functions

6. The Memory and its Hierarchy

- Processor vs. memory speed
- Classes of memory systems, memory hierarchies
- Cost vs. access time
- Random access memory (RAM)
- Read-only memory (ROM)
- Caches
- Virtual memories
- Address translation techniques

7. Software

- System software
- Languages and translations
- Loaders
- Linkers

8. Input/Output

- I/O problem
- I/O addressing
- Data transfer
- Direct memory access (DMA) channel
- Selector channel, multiplexor channel and block multiplexor channel

9. Computer Communication

- Parallel computer networks
- Local area networks
- Wide area networks

10. Computer Classes, Multicomputer and Special-Purpose Systems

- Supercomputers, mainframes, workstations and PC's
- Multiprocessor systems
- Parallel processing
- Distributed systems
- Pipelining
- Real-time systems
- Responsive systems
- Reconfigurable systems
- Fault-tolerant computers
- Computer networks
- Impact of microprocessors on computer organization
- Simulation of computer systems

11. Latest Developments and Trends in Computer Organization: The 21st Century Computing

COMPUTER

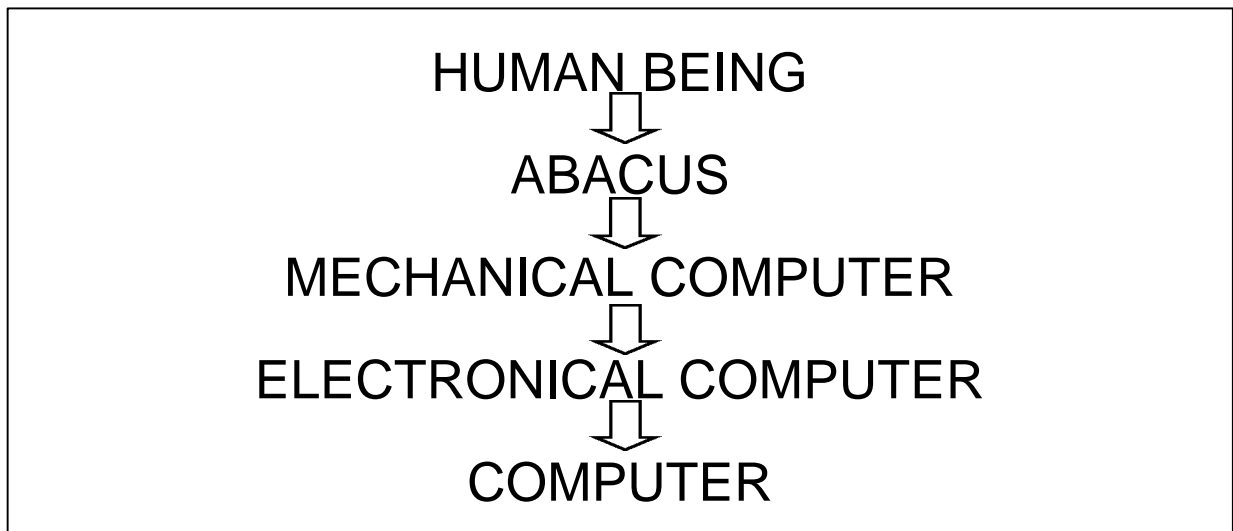
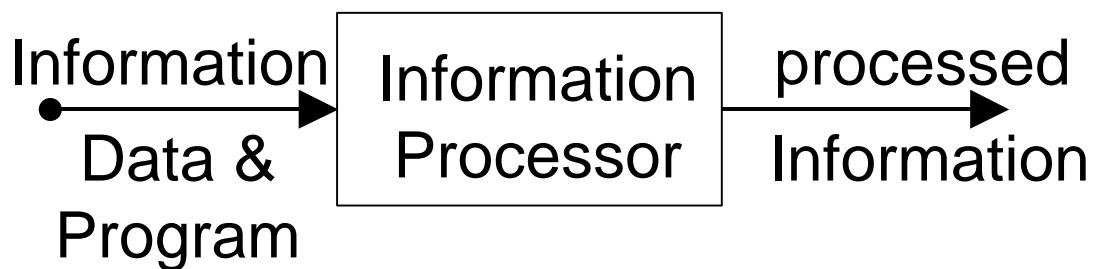
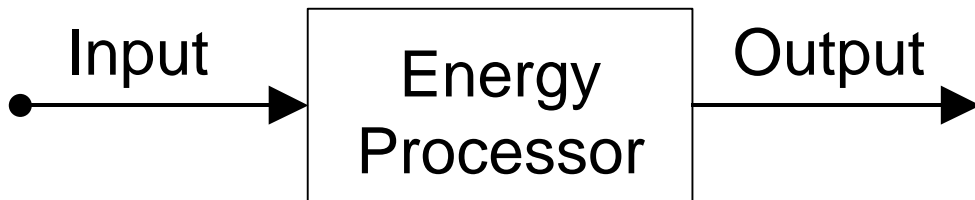

TWO GOALS: SPEED

ACCURACY

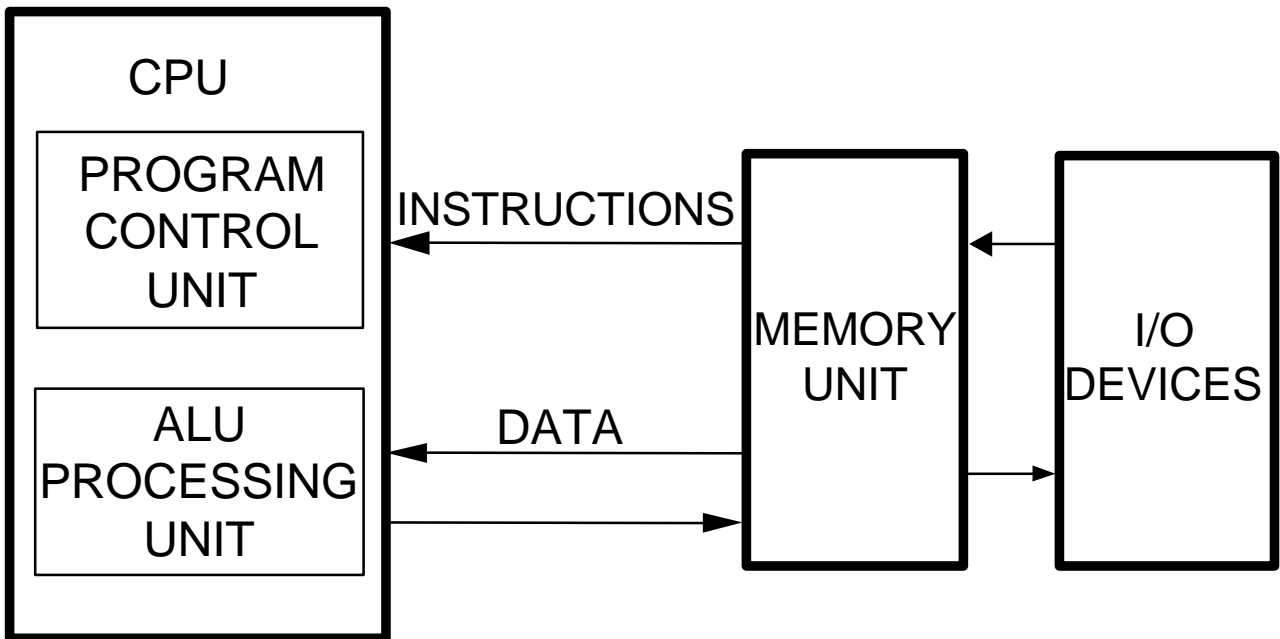
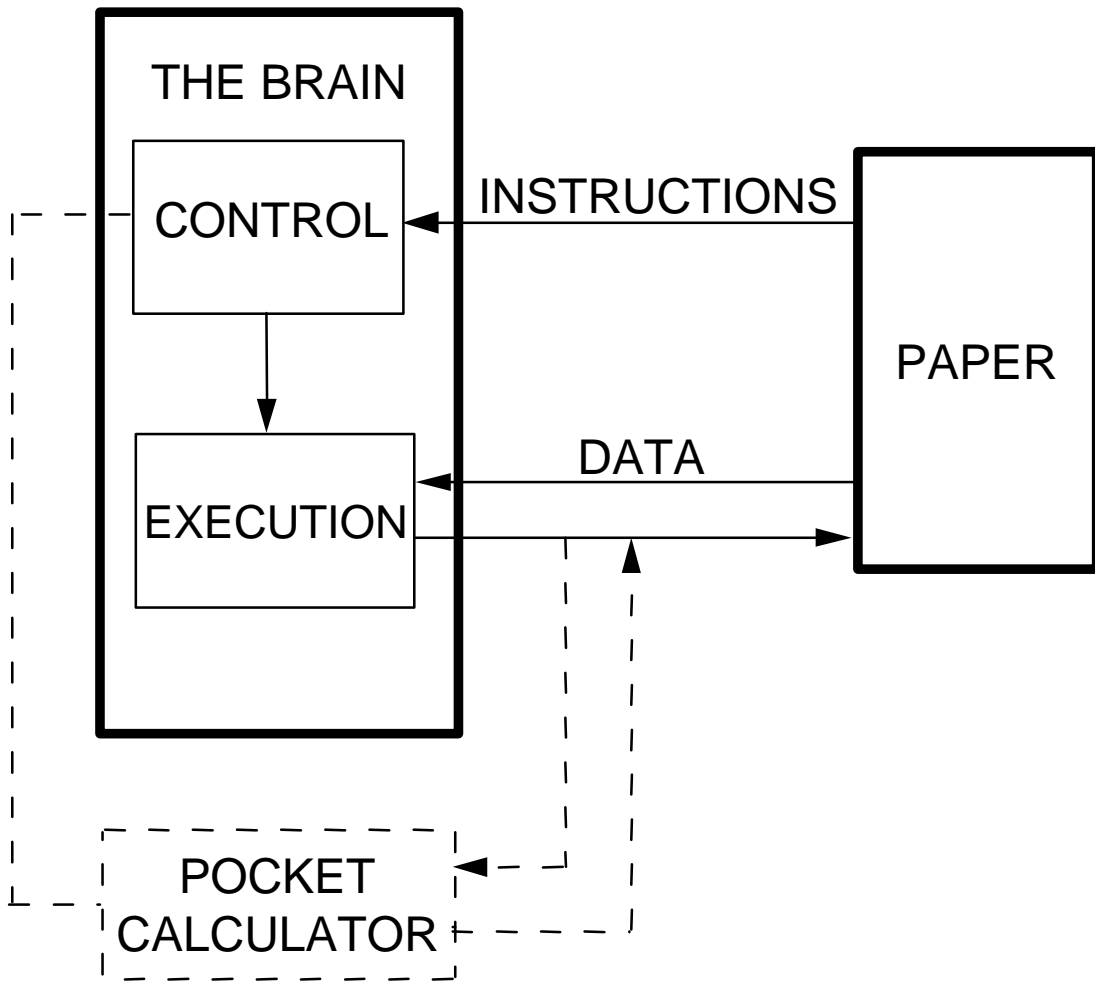

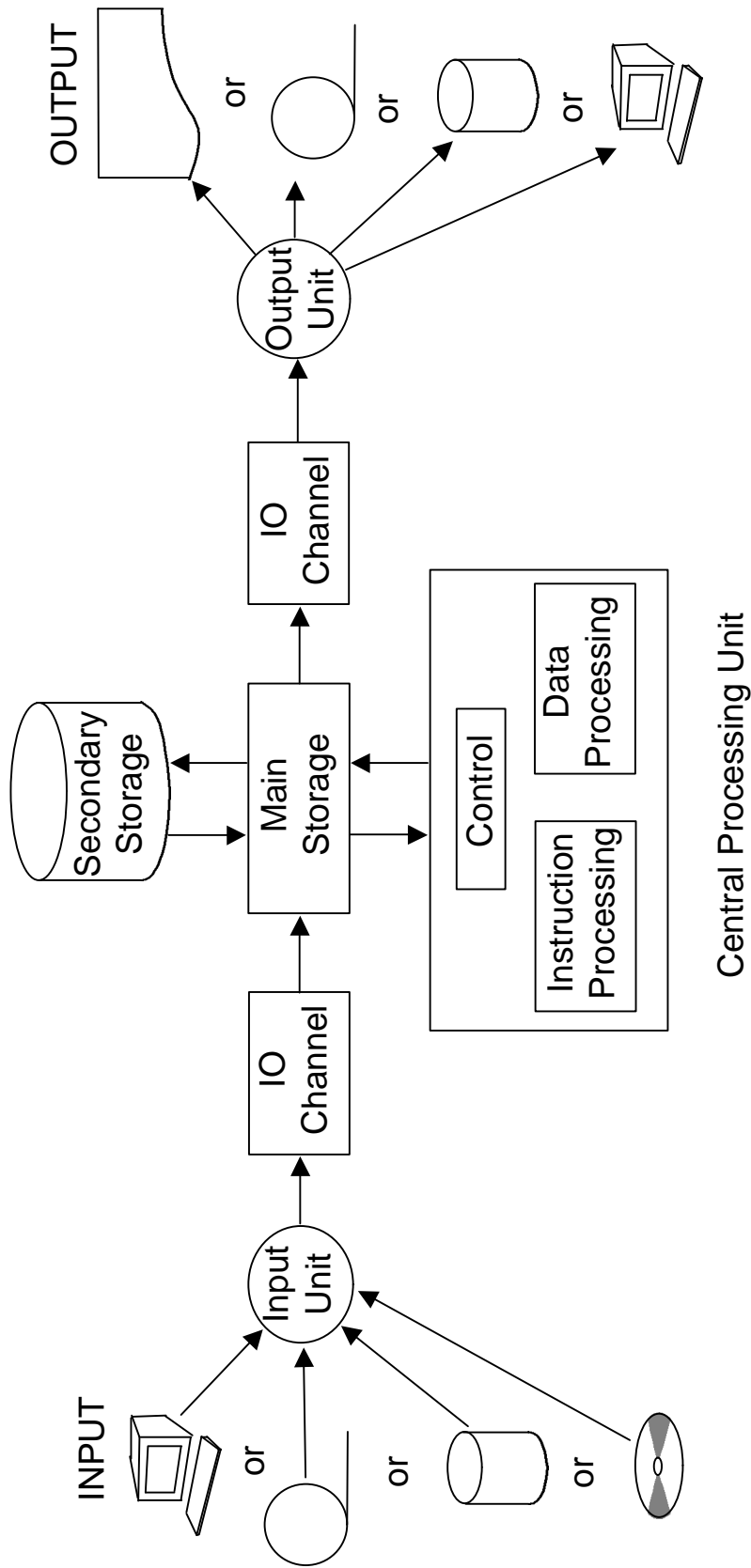

DEFINITIONS

COMPUTERARCHITEKTURE IS

- the Art: to fulfil needs of users
- Structuretheorie: how to build computer systems
- the Art : to form the Design to provide a useful interface

ARCHITECTURE and ORGANIZATION

the perspective
of Programers

the perspective of
the Ingenieurs

THE PARADOX OF COMPLEXITY

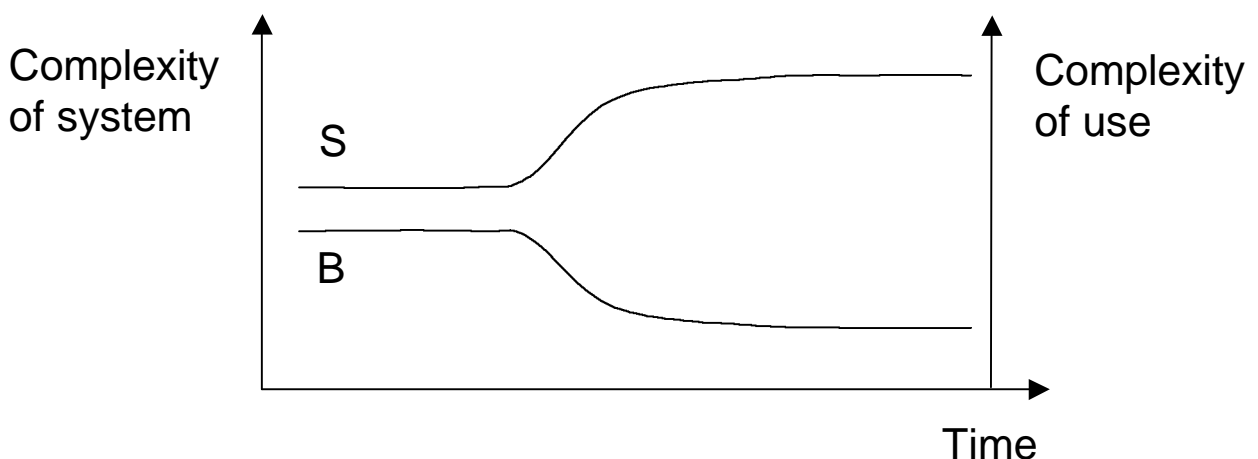

COMPUTER ARCHITECTURE - DEFINITIONS

- Art of determining the needs of the user of a structure and then designing to meet those as effectively as possible within economic and technological constraints. Includes engineering considerations so that the design will be economical and feasible; the emphasis is upon the needs of the user, whereas in engineering the emphasis is upon the needs of the fabricator.
(Planning a Computer System, W. Buchholz ed., McGraw-Hill, 1962, p. 5)
- To describe the attributes of a system as seen by the programmer, i.e. the conceptual structure and functional behaviour as distinct from the organization of the data flow and controls, the logical design and the physical implementation.
(Architecture of IBM System/360, IBM J.R.&D., April 1964, pp.87-101, G. M. Amdahl, G. A. Blaauw, F. P. Brooks)
- The art of designing a machine that will be a pleasure to work with. This art, one cannot call it a science, is one step more abstract than that of a logical designer, which in turn is abstracted from the study of electronic circuits.
(Computer Architecture, C. C. Foster van Nostrand Reingold, 1970)

- The study of Computer Architecture is the study of the organisation and interconnection of components of computer systems. Computer architects construct computers from basic building blocks such as memories, arithmetic units and buses. From those building blocks the Computer Architecture can construct any number of different types of computers.
(Introduction to Computer Architecture, H. S. Stone ed., SRA, Chicago, 1975, p.3)

- The overall design of the system level, the kinds of instructions available, the kinds of data used, the mechanics available for altering the flow of control, the memory organisation and addressing, the relationship between instruction set and memory organization, the method by which the virtual machine is implemented - the topics are sometimes loosely grouped together under the imprecise labels of Computer Organisation or Computer Architecture.
(Structured Computer Organisation, A. S. Tanenbaum, P-H, 1976, p.15)

- The study of the structure, behaviour and design of computers.
(Computer Architecture and Organisation, J. P. Hayes, McGraw-Hill, 1978, p.XI)

- Computer Architecture is a term commonly used to denote the organization and design of digital computers.
(Computer System Architecture, M. M. Mano, P-H, 1976, p.XI)
- The design of the system specifications at a general or subsystem level is called Computer Architecture.
(Principles of Digital Computer Design, Vol. 1, A. M. Abd-Alla, A. C. Meltzer, P-H, 1976, p. 187)
- The “blue-print“ used to build the machine. It is the instruction set and the I/O connection capabilities. Machines with the same architecture can execute the same programs and can have the same I/O devices connected to them. The organisation of a machine is usually shown by a block diagram.
(Developments and Directions in Computer Architecture, Computer, Aug. 1978, pp. 54-67, G. J. Lipovski, K. L. Doty)
- Art, science and/or engineering of computer structure, organization, implementation and performance evaluation.
(Computer Systems Architecture, J. C. Baer, Computer Science Press, 1980, p. VII)

UNDERSTANDING OF PROCESSES AND SYSTEMS

A PROCESS ABSTRACTION

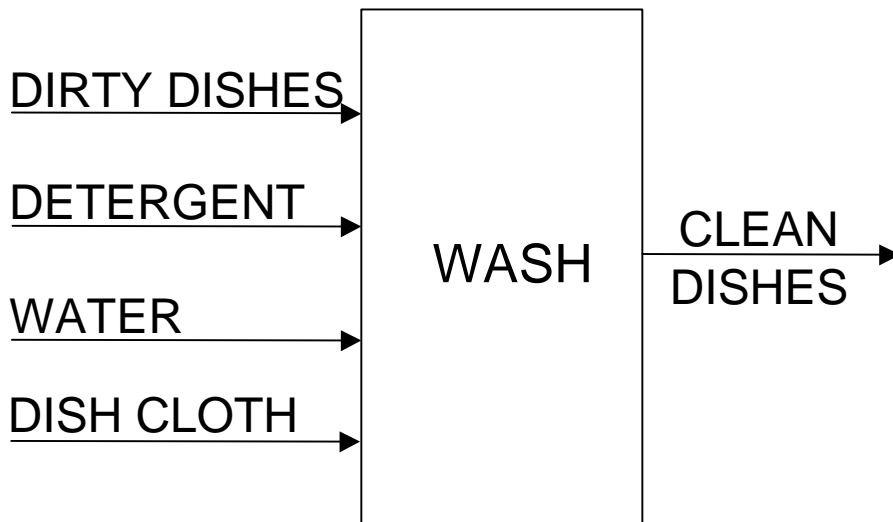

A PROCESSOR

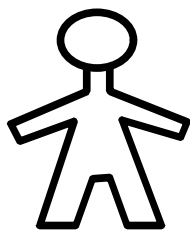

OR

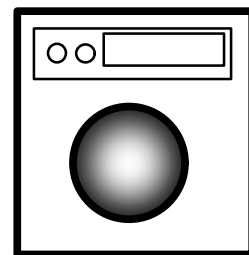

COOPERATING PROCESSES

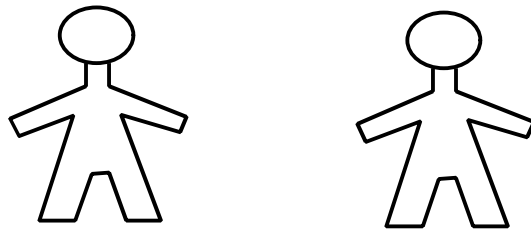
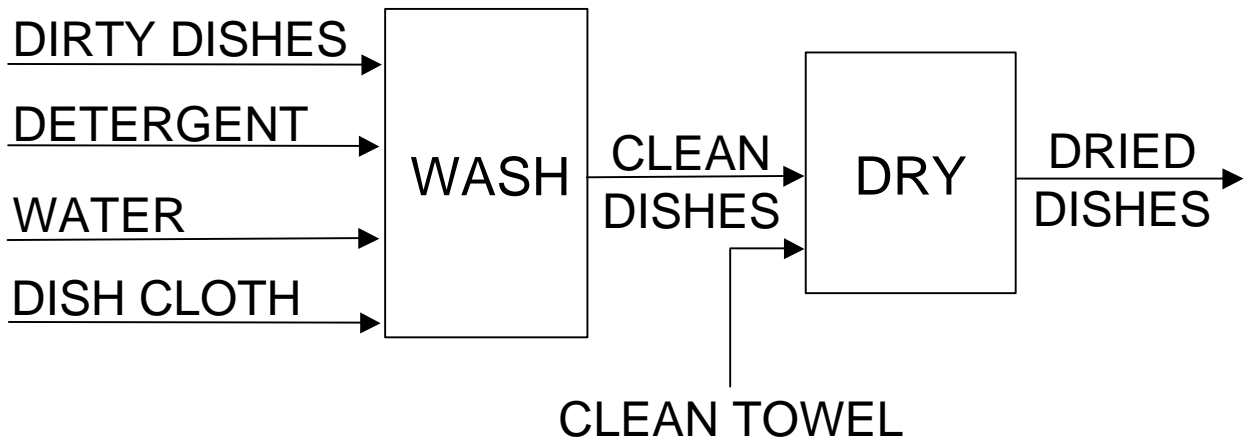

MULTIPROCESSORS

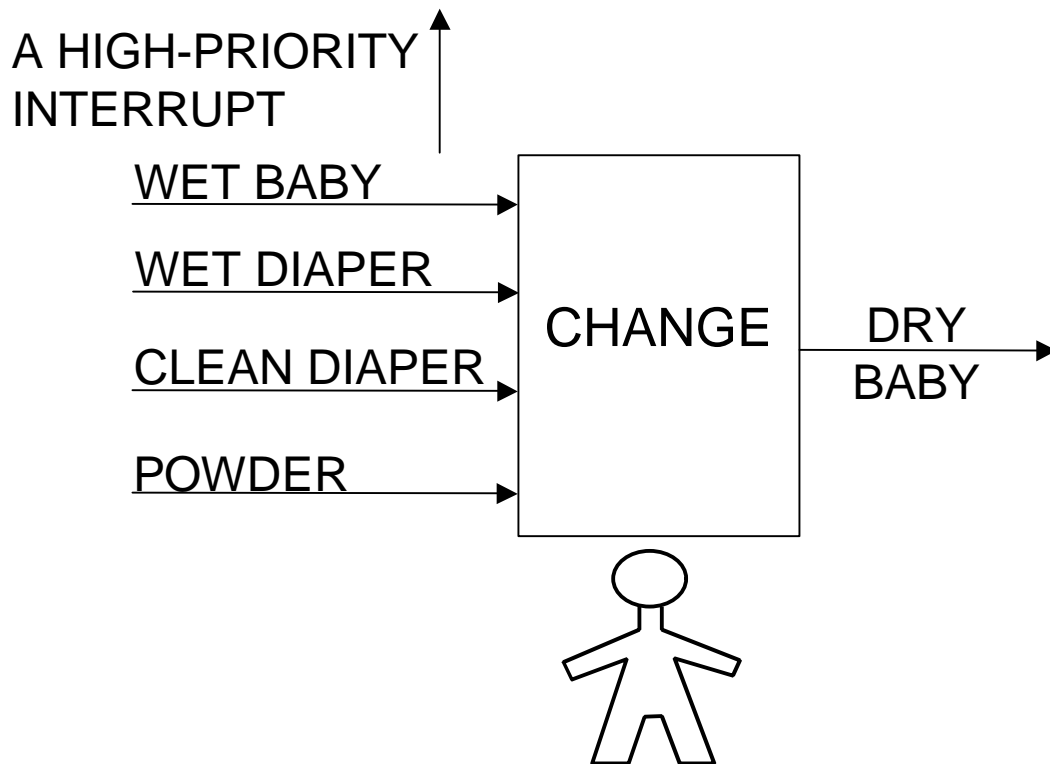

NEW CONCEPTS

PROCESS (TASK)	COOPERATING PROCESSES
PROCESS INPUTS	CONCURRENT PROCESSES
PROCESS OUTPUTS	PARALLEL PROCESSES
PROCESS EXECUTION	INTERRUPT
PROCESS INITIATION	PROCESS PRIORITY
PROCESS SUSPENSION	PROCESS RESUMPTION
PROCESS TERMINATION	

PROCESSOR
SYSTEM
UNIPROCESSOR
MULTIPROCESSOR
PROCESSOR ASSIGNMENT